

PRECISION OCXO IN SMD PACKAGE MV295

Features:

- High stability vs. temperature: up to $\pm 5 \times 10^{-9}$
- Standard 25.4x22x12.5(10.0) mm SMD package
- Oven alarm function
- Power supply: 3.3V, 5V and 12V
- Available as RoHS
- Frequency range: 10.0 – 40.0 MHz

Power supply		Output		Package type	
12 V	5 V	HCMOS		25.4x22x12.5 mm	C12.5
3.3 V				25.4x22x10 mm	C10

ORDERING GUIDE: MV295-C 5 F-12V-HCMOS-C12.5-10.0 MHz

Availability of certain stability vs. operating temperature range (for 10 MHz, 12 V)		$\pm 5 \times 10^{-8}$	$\pm 2 \times 10^{-8}$	$\pm 1 \times 10^{-8}$	$\pm 5 \times 10^{-9}$
		50	20	10	5
A	0...+55°C	A	A	A	A
B	-10...+60°C	A	A	A	C
C	-20...+70°C	A	A	A	C
D	-40...+70°C	A	A	C	C
EX	-40...+85°C	A	C	NA	NA

A – available, NA – not available, C – consult factory

For other temperature ranges see designation at the end of Data Sheet.

Package drawings:

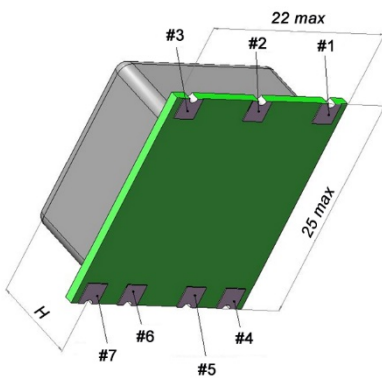

Outputs designations

- #1 – Us (Power supply);
- #2 – Uref (Reference Voltage output);
- #3 – Uin (Control Voltage input);
- #4 – Rf output
- #5 – Oven alarm;
- #6 – NC;
- #7 – GND (Ground).

Vibrations:	
Frequency range	10-500 Hz
Acceleration	5 g

Shock:	
Acceleration	75 g
Duration	3±1 ms

Humidity @ 25 °C	98%
Storage temperature range	-55...+85 °C

Availability of certain aging values for certain frequencies		Standard frequencies, MHz					
		10.0	12.8	15.36	16.384	20.0	25.0
H	$\pm 2 \times 10^{-7}$ / year	A	A	A	A	A	A
G	$\pm 1 \times 10^{-7}$ / year	A	A	A	A	C	C
F	$\pm 5 \times 10^{-8}$ / year	A	A	A	C	NA	NA
E	$\pm 2 \times 10^{-8}$ / year	A	C	NA	NA	NA	NA

Phase noise, dBc/Hz, for 10MHz, 5V and 12V	-
1 Hz	<-90
10 Hz	<-120
100 Hz	<-135
1000 Hz	<-145
10000 Hz	<-150

Short term stability (Allan deviation) per 1 sec, for 10 MHz	< 1×10^{-11}
Frequency stability vs. load changes ($\pm 5\%$)	< $\pm 3 \times 10^{-9}$
Frequency stability vs. power supply changes ($\pm 5\%$)	< $\pm 3 \times 10^{-9}$
Warm-up time within accuracy of $\leq \pm 1 \times 10^{-7}$ @ 25°C	<3 min

Power supply (Us)	12V±5%	5V±5%	3.3V±5%
Steady state current consumption @ +25°C	<90 mA	<215 mA	<320 mA
Peak current consumption during warm-up (for "D" temp. range)	<220 mA	<530 mA	<800 mA
Frequency pulling range (for 10 MHz)	> $\pm 4.0 \times 10^{-7}$		
Control voltage range (Uin)	0...5 V	0...4.5V	0...2.8V
Reference voltage (Uref)	+5 V	+4.5 V	+2.8 V
Output	HCMOS		
Level	12V	>4.5 / <0.5V	
	5V	>4.0 / <0.5V	
	3.3V	>2.4 / <0.4V	
Load	10kOhm/15pF		
Rise/Fall time	<6 ns		
Harmonics	-		

Additional notes:

- Please consult factory for daily aging values. Normally typical correspondence of daily to aging per year is as following: $\pm 1 \times 10^{-7}$ /year – $\pm 1 \times 10^{-9}$ /day; $\pm 5 \times 10^{-8}$ /year – $\pm 5 \times 10^{-10}$ /day; $\pm 3 \times 10^{-8}$ /year – $\pm 3 \times 10^{-10}$ /day
- Please mention RoHS requirement (if any) while requesting for quote or while placing PO.
- For non standard operating temperature ranges please use the following two letters designations (first letter for the lower limit, second letter for the upper limit), °C:

A	B	C	D	E	F	G	H	J	K	L	M	N	P	Q	R	S	T	U	W	X
-60	-55	-50	-45	-40	-30	-20	-10	0	+10	+30	+40	+45	+50	+55	+60	+65	+70	+75	+80	+85